



Test Competition, 5th IJSO, Gyeongnam, Korea, December 9, 2008

5th INTERNATIONAL JUNIOR SCIENCE OLYMPIAD

TEST COMPETITION

December 9, 2008

International Junior Science Olympiad

2008

7 ~ 16 December 2008

GYEONGNAM KOREA

Read carefully the following instructions:

1. The time available is 3 hours.
2. The total number of the questions is 30. Check that you have a complete set of the test questions and the answer sheet.
3. Use only the pen provided.
4. Write down your name, code, country and signature in your answer sheet.
5. Read carefully each problem and choose your correct answer by crossing one of the capital letters in your answer sheet. There is only one right answer for each problem.

Formatted: Bullets and Numbering

Example:

1	A	B	C	D
---	--------------	---	---	---

6. If you want to change your answer, you have to circle the first answer and then cross a new letter as your correct answer. You may only allow making one correction.

Example:

1	⊗ A	B	C	D
---	-------------------	---	---	--------------

A is the first answer and D is the corrected answer

7. All competitors are not allowed to bring any stationary and tools provided from outside. After completing your answers, all of the question and answer sheets should be put neatly on your desk.
8. Point rules :
 - Correct answer : + 1.0 point
 - Wrong answer : 0.25 point
 - No answer : 0.0 point

EXAMINATION RULES

1. All competitors must be present at the front of examination room ten minutes before the examination starts.
2. No competitors are allowed to bring any tools except his/her personal medicine or any personal medical equipment.
3. Each competitor has to sit according to his or her designated desk.
4. Before the examination starts, each competitor has to check the stationary and any tools (pen, ruler, calculator) provided by the organizer.
5. Each competitor has to check the question and answer sheets. Raise your hand, if you find any missing sheets. Start after the bell rings.
6. During the examination, competitors are not allowed to leave the examination room except for emergency case and for that the examination supervisor will accompany them.
7. The competitors are not allowed to bother other competitor and disturb the examination. In case any assistance is needed, a competitor may raise his/her hand and the nearest supervisor will come to help.
8. There will be no question or discussion about the examination problems. The competitor must stay at their desk until the time allocated for the examination is over, although he/she has finished the examination earlier or does not want to continue working.
9. At the end of the examination time there will be a signal (the ringing of a bell). You are not allowed to write anything on the answer sheet, after the allocated time is over. All competitors must leave the room quietly. The question and answer sheets must be put neatly on your desk.

Formatted: Bullets and Numbering

TEST COMPETITION

1. A piece of aluminum with a density of 2.7 g/cm^3 was hung on a spring scale by a massless string. When we weighed this metal submerged in water with a density of 1.0 g/cm^3 , the scale indicated 200 N. When we weighed this metal submerged in an unknown fluid, the scale indicated 220 N. What is the specific gravity (the ratio of the density of the fluid to density of water) of this unknown fluid?

(A) 0.83 (B) 0.91 (C) 1.10 (D) 1.17

2. You often notice the statement Objects in the mirror are closer than they appear on side mirrors attached on the car. Which is the correct explanation of this statement?

(A) When you see distant objects in a mirror, they always appear closer.

(B) Since the driver is distant from the mirror, objects appear farther as much as the distance between the driver and the mirror.

(C) Since the side mirror has a convex shape, it can make objects appear closer than their actual distance.

(D) When you look in a convex mirror, objects appear farther since objects look smaller than their actual size.

3. If switch ? is opened (switch-off) in the following electric circuit, how does the brightness of the light bulb A and C change? Assume that these bulbs are identical.

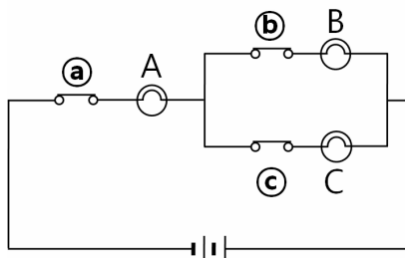

(A) The brightness of bulb A remains the same, but the brightness of bulb C increases.

(B) The brightness of bulb A remains the same, but the brightness of bulb C decreases.

(C) The brightness of bulb A decreases, but the brightness of bulb C increases.

(D) The brightness of bulb A decreases, and the brightness of bulb C decreases.

4. Assume that a block lies on a sufficiently long incline. If one side of the incline is gradually lifted up from 0° to 90° , which graph represents the frictional force acting on the block as a function of the inclined angle? Here the coefficient of static friction is larger than the coefficient of kinetic friction.

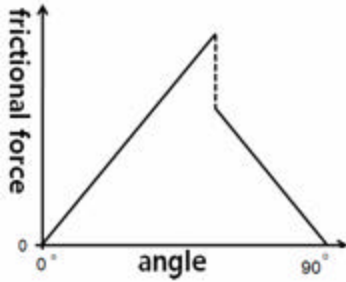

(A)

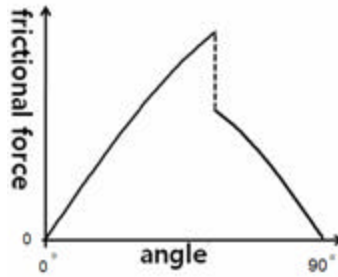

(B)

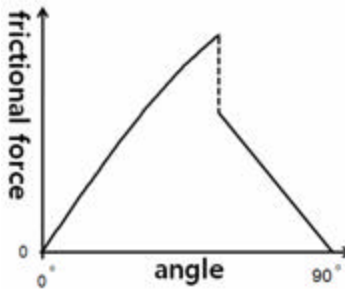

(C)

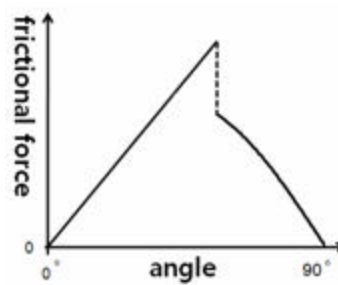

(D)

5. Car A of mass 500 kg is traveling at 100 km/h and Car B of mass 1000 kg is traveling at 50 km/h on a horizontal road. When the drivers stepped on the brakes hard enough so that the brakes were locked instantly, both cars skidded to a stop. What are the ratios of stopping time and stopping distance of Car A and Car B? Assume that both cars move straight and the coefficients of friction between the tire and the surface of the road are the same for both cars, and the air resistance may be neglected.

stopping time (Car A:Car B)

stopping distance (Car A:Car B)

(A) 1:1

2:1

(B) 2:1

2:1

(C) 2:1

4:1

(D) 4:1

4:1



6. Two rain droplets of different sizes start to fall from the same height. Assume that both droplets are spheres with the same uniform density, and the air resistance is proportional to the cross sectional area of the droplet. Which droplet reaches the ground first and for which droplet is the air resistance larger just before the droplet reaches the ground?

droplet which reaches the ground first droplet for which the air resistance is larger

- | | |
|---------------------|-----------------|
| (A) the bigger one | the bigger one |
| (B) the bigger one | the smaller one |
| (C) the smaller one | the bigger one |
| (D) the smaller one | the smaller one |

7. When an astronaut stands on a scale in the ISS (International Space Station) with his/her feet in the direction towards Earth, the scale reading remains the same as before (does not change). Which of the following explains this phenomenon correctly? Assume that the ISS is circling around Earth with a constant speed.

- (A) No gravitational force is acting on the astronaut.
- (B) Although the gravity of Earth is acting on the astronaut, it is canceled out by the normal force between the astronaut and the scale.
- (C) The normal force between the astronaut and the scale is zero.
- (D) There is no force acting on the scale.

8. A supersonic airplane is flying straight and horizontally at the altitude of 5 km above the ground. If the speed of the airplane is Mach 2 (twice the speed of sound in air), what is the closest estimated distance between the observer on the ground and the airplane at the moment the observer hears the sonic boom?

- (A) 10 km (B) 14 km (C) 17 km (D) 20 km



9. The most abundant element in the atmosphere of Jupiter is hydrogen. The Earth's atmosphere has a very small amount of hydrogen. Choose an answer which includes all the correct statements. The hydrogen amount is different because -

- a. the temperature of a planet's atmosphere is lower as the planet is farther away from the sun.
- b. the mass of Jupiter is significantly larger than the mass of Earth.
- c. hydrogen has escaped out of the Earth's atmosphere.
- d. most of the hydrogen is contained inside Earth in the form of chemical compounds.

(A) a (B) a, b (C) a, b, c (D) a, b, c, d

10. In 3rd century BC, Eratosthenes observed the shadows of objects in Alexandria and in Syene at noon of the summer solstice. He observed that the sunlight inclined 7.2° from the vertical in Alexandria, while 0° from the vertical in Syene. He calculated the radius of Earth from this result.

Which of the following is the correct combination of assumptions that he used?

- a. Light rays travel straight.
- b. Sunlight rays falling on the Earth are parallel to each other.
- c. Earth has a spherical shape.

(A) a and b only (B) a and c only (C) b and c only (D) all of the above

11. How much current is needed to produce 10000 kg/day of Fe metal from molten Fe_2O_3 ? The atomic weights of Fe and O are 55.85 and 16.00, respectively. A mole of electrons has a charge of 96500 Coulomb (Faraday's constant).

- (A) 6×10^2 A
- (B) 6×10^3 A
- (C) 6×10^4 A
- (D) 6×10^5 A

12. An element X is the second most abundant in the Earth's crust by mass. Quartz is one of its oxide forms. What is this element?

(A) silicon (B) carbon (C) aluminum (D) magnesium

13. A phase diagram shows pressure and temperature conditions at which stable phases can occur. The figure below is the phase diagram of CO₂. Which of the following is an incorrect statement, based on this diagram? (1 atm = 1.01325 x 10⁵ Pa, 1 atm = 1.01325 bar)

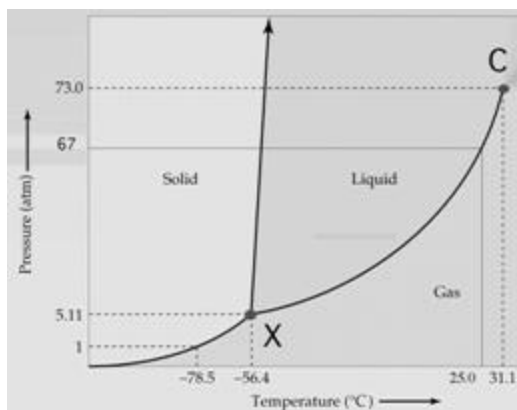

- (A) X is the triple point of CO₂, where three different phases coexist.
- (B) C is the critical point of CO₂, where liquid and gaseous phases become indistinguishable.
- (C) Under the atmospheric pressure, gaseous CO₂ can be liquid when the temperature is reduced.
- (D) At room temperature (25 C), gaseous CO₂ can be liquid when the pressure increases.

14. Gaseous ammonia (NH₃) can be decomposed to gaseous N₂ and gaseous H₂. What are the volumes of gaseous N₂ and H₂ when 17.0 mL of gaseous NH₃ is completely decomposed? Assume that the pressure and temperature of the reaction flask are kept constant. Gases are assumed to be ideal gases. (mL = milliliter)

- | | <u>Volume of N₂</u> | <u>Volume of H₂</u> |
|-----|--------------------------------|--------------------------------|
| (A) | 8.50 mL | 25.5 mL |
| (B) | 17.0 mL | 34.0 mL |
| (C) | 25.5 mL | 51.0 mL |
| (D) | 17.0 mL | 51.0 mL |

15. The first ionization energy (IE_1) of an element is defined by the minimum energy needed to remove an outermost valence electron from its atomic ground state in gas phase. Which of the following elements has the largest IE_1 ? The ground state electron configuration of each element is shown in the parenthesis.

(A) B ($1s^2 2s^2 2p^1$) (B) C ($1s^2 2s^2 2p^2$) (C) N ($1s^2 2s^2 2p^3$) (D) O ($1s^2 2s^2 2p^4$)

16. The reaction between calcium carbonate (CaCO_3 , molar mass 100) and gaseous hydrogen chloride (HCl) produces solid calcium chloride (CaCl_2), gaseous carbon dioxide (CO_2), and liquid water (H_2O). What is the volume of CO_2 generated when 20 g of CaCO_3 reacts with 20 mL of HCl at 1 atm and 25°C ?

(A) 4500 mL (B) 450 mL (C) 10 mL (D) 5.0 mL

17. For a weak acid HA, the acid dissociation constant (K_a) is defined as follows:

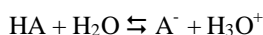

$$K_a = \frac{[\text{A}^-][\text{H}_3\text{O}^+]}{[\text{HA}]}$$

The pH of a solution is a measure of the molar concentration of hydrogen ions in the solution. The numerical value is defined as $\text{pH} = -\log_{10}[\text{H}_3\text{O}^+]$. From the definitions of K_a and pH, we get a convenient relationship between K_a and pH.

$$-\log_{10} K_a = \text{pH} - \log_{10} \left\{ \frac{[\text{A}^-]}{[\text{HA}]} \right\}$$

When a weak acid (HA) is titrated with a standard base (NaOH solution), the following titration curve is obtained.

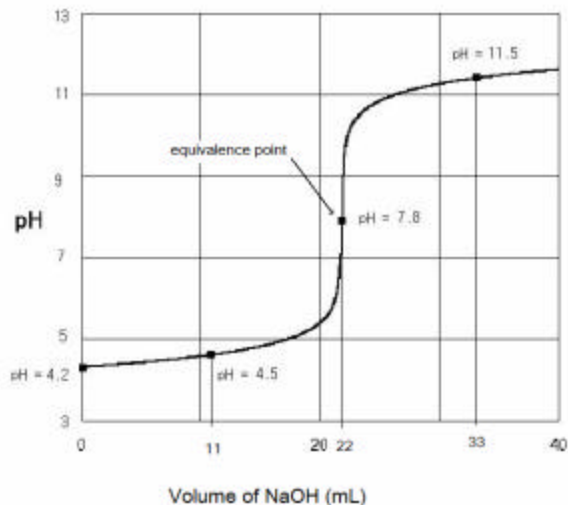

Using the titration curve and the pH data, calculate the dissociation constant K_a of acid HA.

- (A) $10^{-4.2}$ (B) $10^{-4.5}$ (C) $10^{-7.8}$ (D) $10^{-11.5}$

18. Same amount of distilled water was poured into two identical beakers, and the beakers were placed in separate identical boxes. The boxes were then sealed. The equilibrium temperatures of the boxes reached to 10°C (Box A) and 20°C (Box B), respectively. Which of the following is a correct statement? Gases are assumed to be ideal gases.

- (A) Both boxes have the same number of water molecules in gas phase.
 (B) The ratio of average kinetic energy of gas molecules in the two boxes (Box B:Box A) is 293:283.
 (C) The ratio of average speed of gas molecules in the two boxes (Box B:Box A) is $\sqrt{2}:1$.
 (D) The water vapor pressure inside Box A is larger than that of Box B.

19. The relative humidity is defined as the percent ratio of the partial pressure of water to the saturated water vapor pressure.

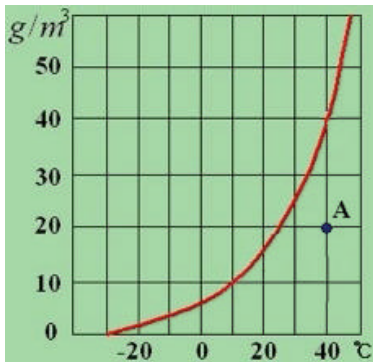

Based on the water vapor saturation curve in the figure, estimate the relative humidity at the state A.

- (A) 20 % (B) 25 % (C) 50 % (D) 100 %

20. Which of the following chemical species has the largest ionic radius?

- (A) Na^+ (B) Mg^{2+} (C) F^- (D) O^{2-}

21. A wisteria (dicot plant) branch was cut and put in red ink. After 3 hours, the leaves as well as the stem turned red.

I. Stem

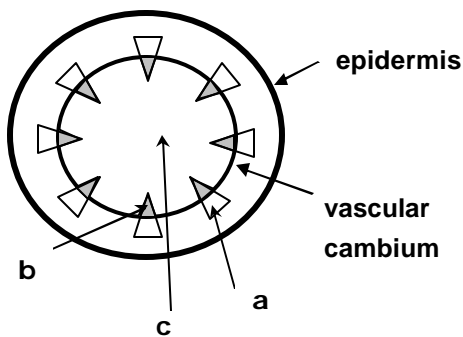

II. Leaf

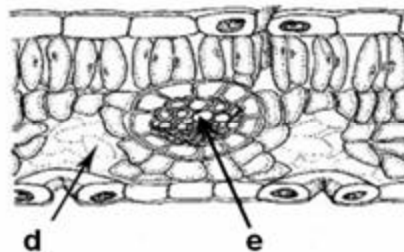

Select the parts which have turned red first in the cross sections I (stem) and II (leaf).

- (A) a, d (B) a, e (C) b, e (D) c, d

22. The following pedigree illustrates the inheritance of an inability to taste. Persons unaffected or affected with a trait is indicated in the following box. The normal allele is designated as T, and the allele causing inability to taste as t.

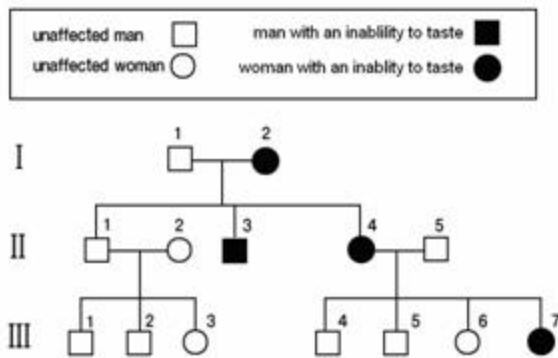

Which of the following statements regarding the pedigree is true?

- (A) The probability that II-1 is heterozygous is $1/2$.
- (B) The genotype of II-5 can be either Tt or TT.
- (C) Based on the given information, the number of people with undeterminable genotypes is 4.
- (D) If II-4 and II-5 couple has 2 more children, the probability that they are both girls with taste blindness is $1/8$.

23. The table shown below is the analytical data of mitochondrial DNA of four different, but related animal species.

DNA sequence

	1	2	3	4	5	6	7
I	A	G	G	G	G	G	T
II	G	G	G	A	G	G	G
III	G	A	G	G	A	A	T
IV	G	G	A	G	A	A	G

If you made a phylogenetic tree of these four animals with the data above, which would be the correct answer? (You should consider the fewest change of sequence of bases in DNA)

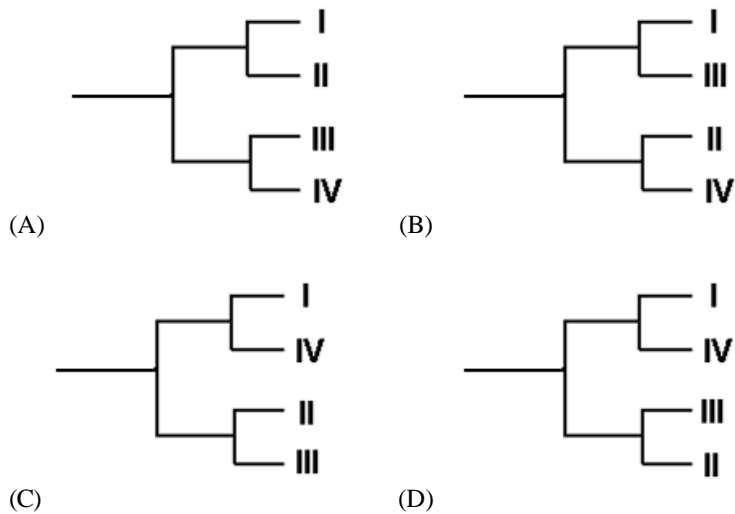

24. Birth records of four babies were mixed up by mistake at a hospital. The ABO blood types of their parents were found as shown in the following table.

		Blood type
parents W	father	A
	mother	AB
parents X	father	O
	mother	O
parents Y	father	AB
	mother	O
parents Z	father	A
	mother	O

Given these four babies all have different blood types, which of the following statements is true?

- (A) parents W: baby blood type – B
- (B) parents W: baby blood type – AB
- (C) parents Y: baby blood type – A
- (D) parents Y: baby blood type – AB

25. The diagram below shows a typical foodweb of a rice paddy.

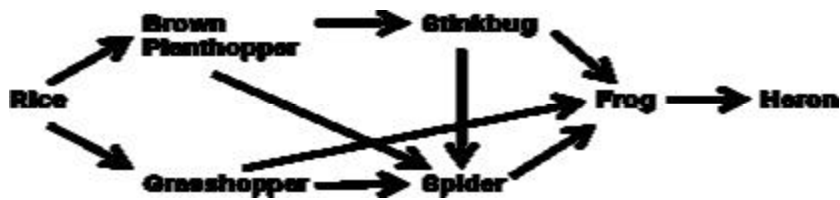

Regarding this foodweb, which of the following statements are true?

- (a) Biomass decreases as you go up the trophic level in this foodweb.
- (b) Heron has the most impact on this ecosystem.
- (c) If the number of spiders decreases, the number of brown planthoppers will increase.
- (d) If the number of heron increases, the amount of rice will increase.
- (e) If the number of grasshoppers increases, the amount of rice will decrease.

- (A) a, e (B) b, d (C) a, c, d (D) b, c, e

26. The graph below shows experimental results which regards hatching of fruitfly eggs. A researcher hatched fertilized eggs at 10°, 15°, 20°, 30° after they were incubated at 2° (Exp. I) or at 21° (Exp. II) for 3 days.

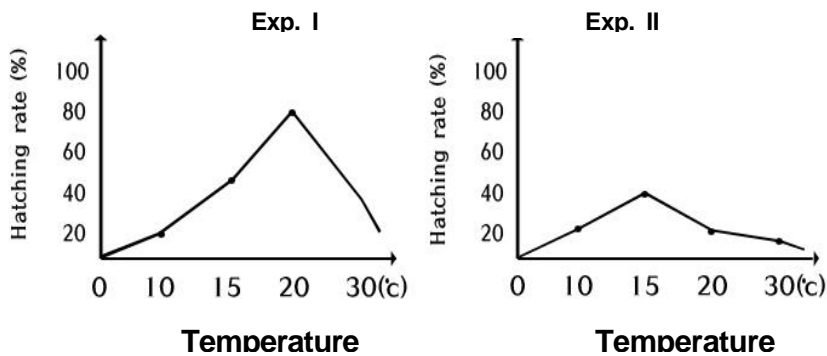

Select an option with the optimum incubation temperature and optimum hatching temperature.

	incubation temperature(?)	hatching temperature(?)
(A)	2	30
(B)	2	21
(C)	21	15
(D)	21	21

27. Seals can dive for about an hour without coming up to the surface of the ocean. Which of the following is incorrect in explaining how seals do this?

- (A) Seals have sufficient oxygen because they have relatively high blood volume compared to other animals .
- (B) Seals enhance oxygen transport to tissues by increasing heartbeat frequency.
- (C) Seals have constriction of blood vessels leading to most tissues except the neuronal system, heart, and eyes.
- (D) Seals reduce the rate of metabolism in their muscles.

28. The following experiment shows how leaf positioning is affected by different lights. Seedlings were placed under red and/or blue, or white light source for several hours. Angle (?) of petiole was measured and the results were represented as the graph below.

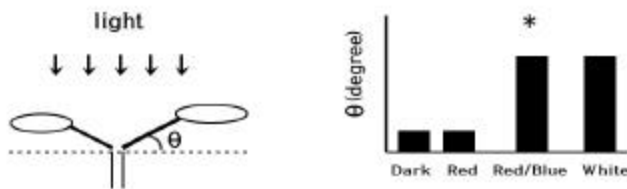

Which of the following is a valid statement regarding this experiment?

- (A) Red light makes angle ? larger.
- (B) Angle ? is generally smaller when seedlings are exposed to sun light than when exposed to blue light.
- (C) Blue light is the major light which affects leaf positioning.
- (D) Angle ? will be larger than that of ' * ' marked result when seedlings are illuminated by red light from above and blue light from the side.

29. Methionine is used to synthesize proteins in cells. To determine the intracellular protein transport pathway, pancreatic cells were cultured for 30 seconds in media containing ³⁵S-labeled methionine and then were transferred to fresh media with no radioisotopes. After 5 minutes, 30 minutes, and 120 minutes, respectively, cell organelles(a, b, c) were purified and the radioactivity of each sample was measured. The following graph shows the results.

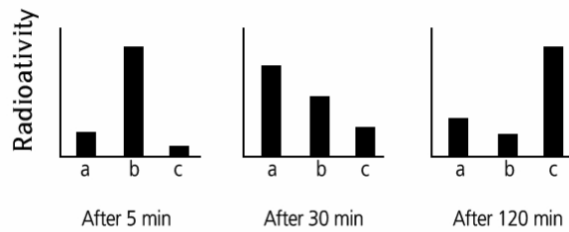

Which of the following is the correct steps of the intracellular protein transport pathway?

- (A) a? b? c (B) a? c? b (C) b? a? c (D) b? c? a

30. Estrogen influences the menstrual cycle by binding to the α and β receptors of the endometrial cells of the uterus. Many women gain weight as the amount of estrogen decreases after menopause. A mouse with ovaries removed usually gains weight; however, if this mouse is injected with estrogen, it does not gain weight. If the mouse, with ovaries removed, is injected with a substance which can activate the α receptor, it doesn't gain weight. But when mouse with ovaries removed is injected with a substance which can activate β receptor, it gains weight.

Which of the following statements is valid?

- (A) The substance which can activate α receptor inhibits the secretion of estrogen.
 (B) Estrogen inhibits weight gain through activating the α receptor.
 (C) Estrogen inhibits weight gain through activating the β receptor.
 (D) Estrogen inhibits weight gain through inactivating the β receptor.